

DTMF Mute Model Silencer II

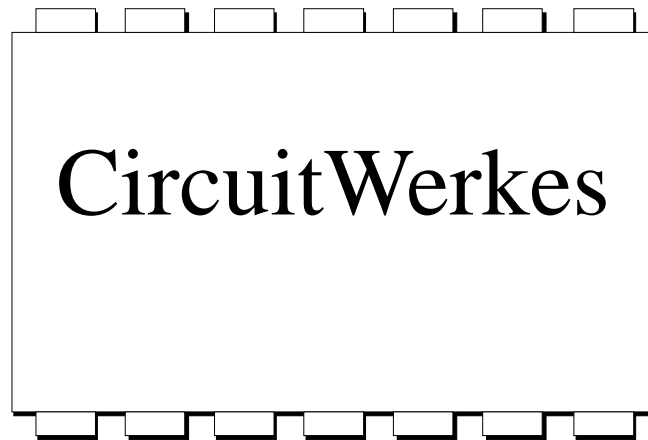

Technical Manual

CircuitWerkes

3716 SW 3rd Place · Gainesville, FL 32607

(352) 335-6555 · Fax (352) 380-0230

<http://www.circuitwerkes.com>

e-mail: info@circuitwerkes.com

Silencer II Technical Manual

The Silencer II is a stand-alone DTMF muting device designed to pass high quality audio (from whatever source is feeding the device) without undesired Touch-Tones.

Audio containing DTMF tones is fed into the Silencer II's input jack and audio minus the DTMF tones is fed from the output jack. The Silencer II contains a DTMF decoder and an audio delay. Anything the DTMF decoder detects as a valid DTMF tone gets muted from the Silencer's audio output. An integral 50 millisecond audio delay in line with the audio output ensures that the muting action occurs just before the tone makes it to the balanced audio output.

Getting Started Quickly

Both input and output jacks are active balanced. When driving unbalanced loads, the negative (ring) lead should be left floating. The unit is set for unity gain and optimized for 0dBm input. Simply connect input, output and power and the Silencer II will work.

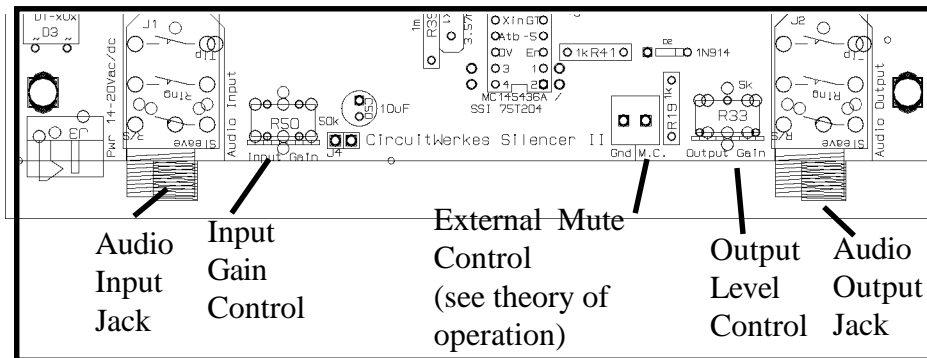

The pages that follow contain a parts layout for the Silencer II board and a schematic and short theory of operation. If you experience trouble with your Silencer II or need assistance, please feel free to call us at (352) 335-6555 or e-mail us at support@circuitwerkes.com.

The Silencer II PC Board Layout

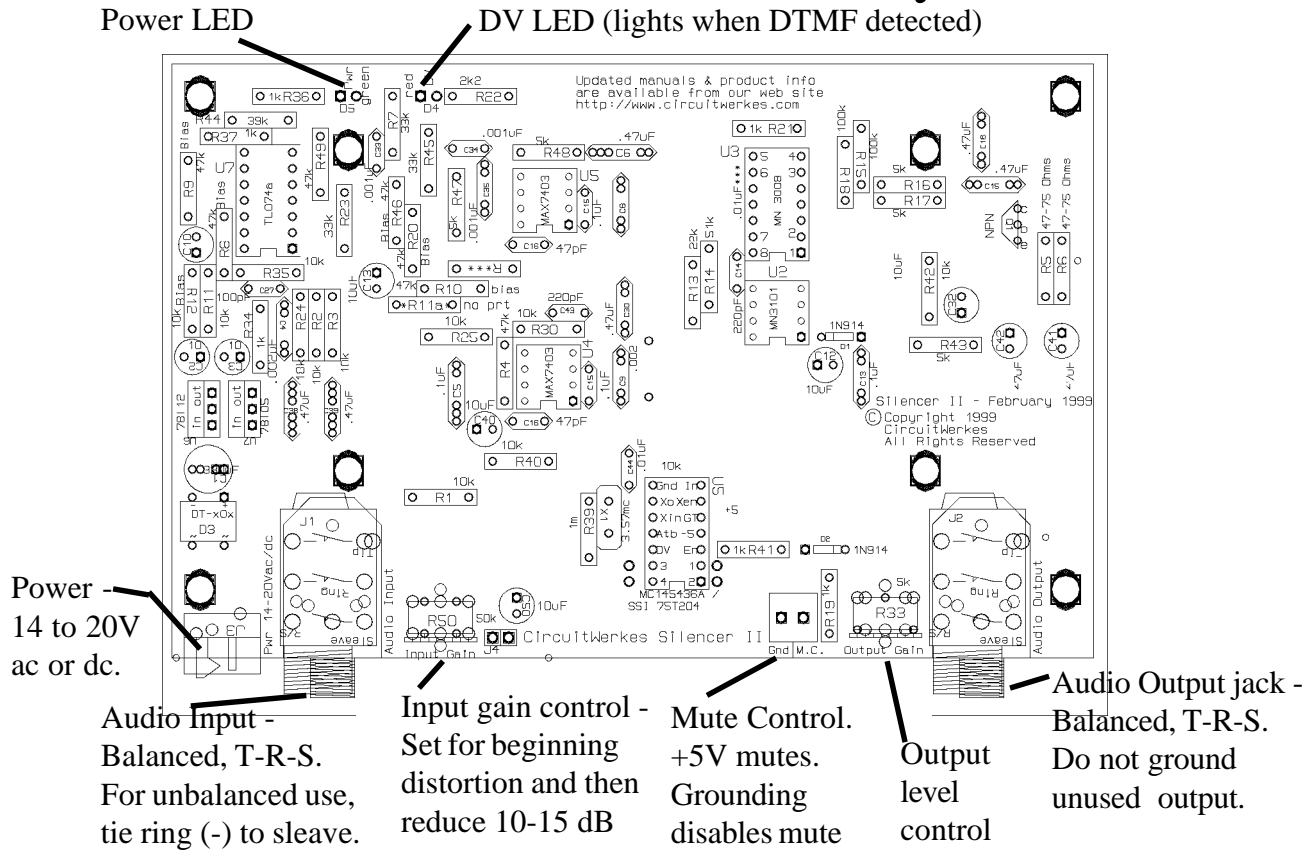

The only user adjustments on the silencer board are input and output level adjust pots. The input level adjust can be optimized for best S/N ratio when dealing with varying input levels such as applications where the input audio peaks at -10dBm (audio from an FCC registered telephone coupler like our AC). To adjust the level, send in a tone at whatever level you will be using. Turn the output level control down so that the output is at -10dBm. If, during input level setting, the output rises above 0dBm, decrease the output level control as needed. Increase the input level until clipping is observed or heard, while making sure that the output level does not rise above 0dBm. Once clipping is observed, decrease the input control so that the output level falls by 15dB. Then set the output control to the desired level, keeping in mind that 10 to 15dB of headroom should be maintained.

Theory of Operation:

Incoming audio is buffered by U7a and routed to U4, a MAX 7403, switched capacitor filter through the input level control pot. This pot is factory set for 0dBm inputs. The filter chip is configured to limit generation of aliasing noise in the next stage. The conditioned audio is fed to Analog delay chip U3. U2 generates the appropriate (approximately 21kHz) clock for U2's operation as a 50msec delay line. The delayed output has a 21kHz clock component that is virtually eliminated by switched capacitor lowpass filter U5. Before the audio gets to U5 it connects in an AC-coupled-only node to the mute circuit made up of q1 and its associated components. DTMF detection is provided by an MC145436 DTMF decoder IC. When a valid DTMF-tone is detected, it activates the mute circuit on the Silencer. The muted circuit simply shunts the audio to ground for the duration of the incoming tone. The filtered, delayed audio from the output of U4's filter is amplified by opamp U7. The Opamp is set up to provide a balanced transformerless output. External control of the mute function is provided at the screw terminal M.C. Grounding this terminal prevents the mute from operating while supplying 5V at the terminal mutes the output regardless of if a tone is detected.

The Silencer II by CircuitWerkes Audio Delay / Mute Board

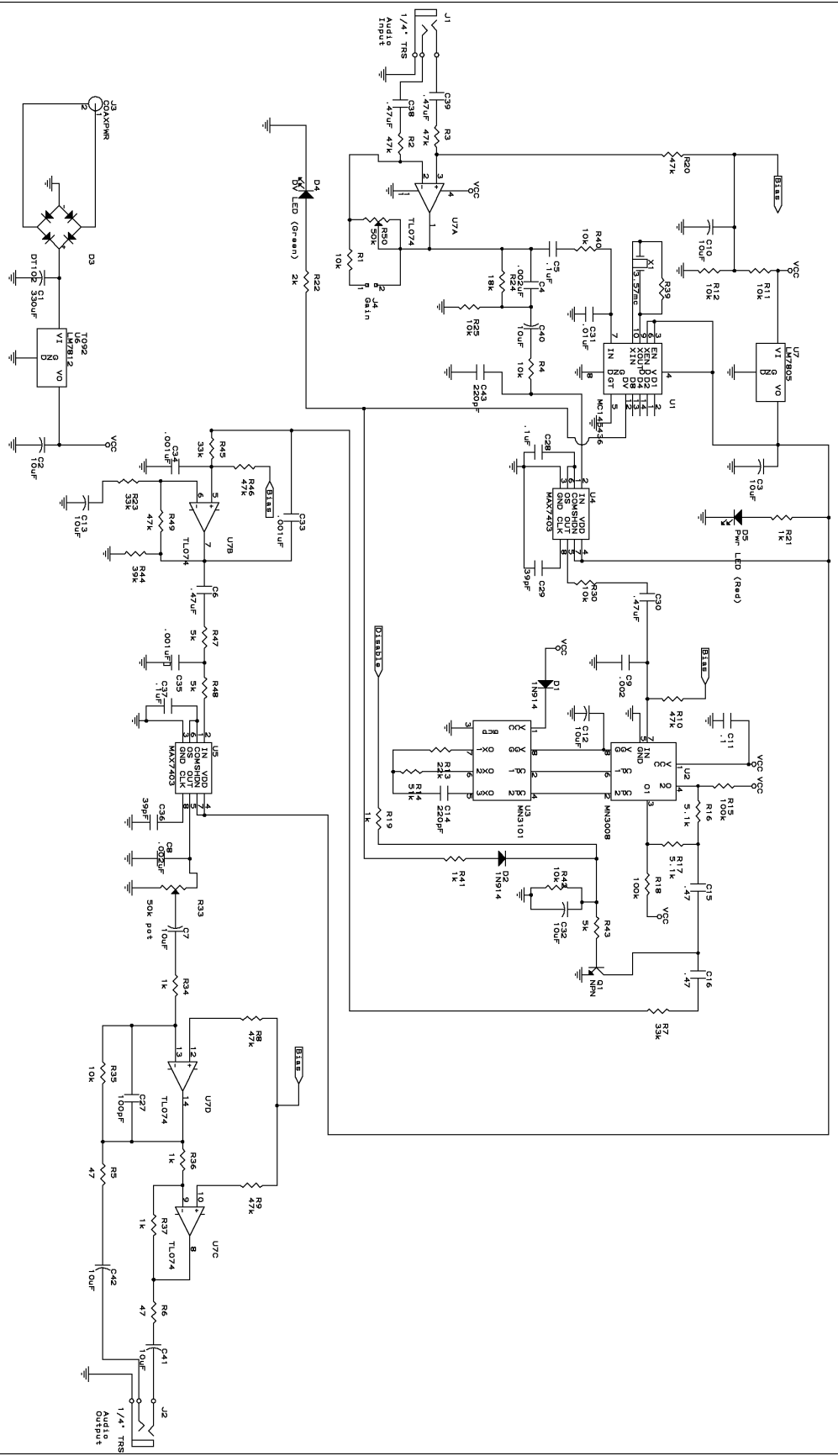

Last used:
 C42 3716 SM 3rd Place
 C43 3716 SM 3rd Place
 C44 (352) 335-6595 (fax) 380-0230
 C45 3716 SM 3rd Place
 R30 Internet: www.circuitwerkes.com
 R31 XI
 Not Used:
 R25-29, 31-32, 38
 C1
 REV H